

真空泵 / Vacuum Pump

型式 **DP0410T-Y1**

PWM control possible

采用无炭刷马达
/ Brushless DC Motor
(12 V DC)

真空专用

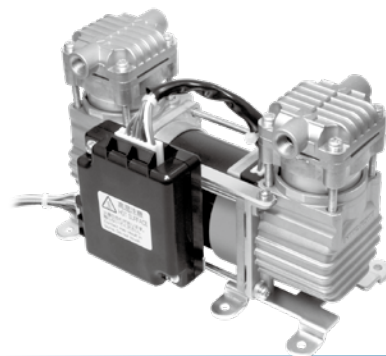

空气量和消耗功率 / Airflow & Electric Current

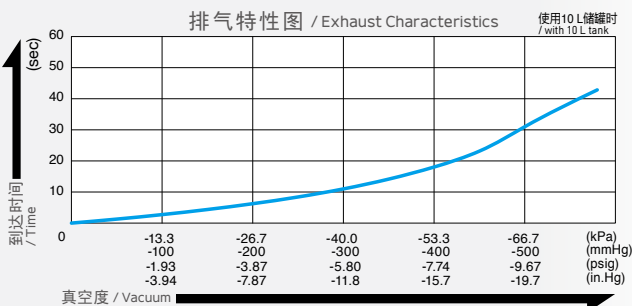
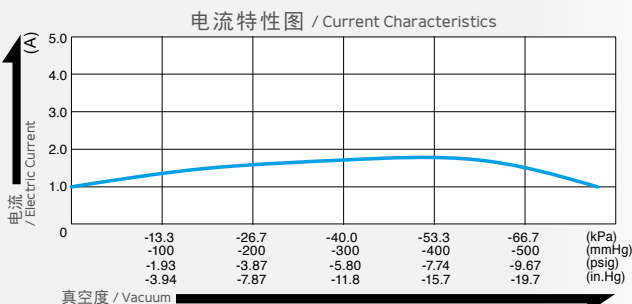
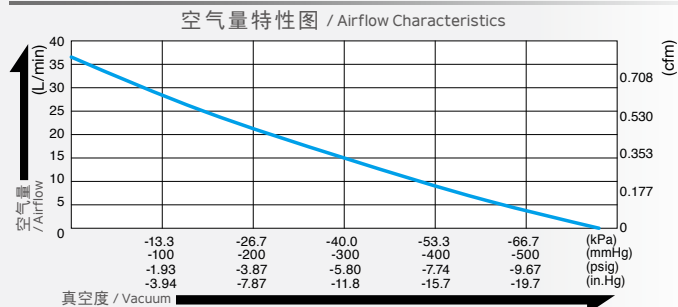

* 特性图只是参考值，并不是保证值。
/ The characteristic charts are for reference only and are not guaranteed.

规格 / Specifications

达到真空度 / Attainable Vacuum	-77.3 kPa (-580 mmHg) -773 mbar -22.8 in.Hg
吐出空气量 / Free Air Displacement	34 L/min 1.2 cfm
额定电压 / Rated Voltage	24 V DC
最大电流 / Maximum Current	2.5 A
额定时间 / Duty Cycle	连续 / Continuous
耐用时间 (MTTF) / Rated Performance (MTTF)	5,000 小时 / hours
吸入口尺寸 / Inlet	Rc1/8 (内螺纹 / internal thread)
吐出口尺寸 / Outlet	Rc1/8 (内螺纹 / internal thread)
线圈绝缘等级 / Coil Insulation Class	相当于 E 类 (对于 DC 电机) E or its equivalent (For DC motor)
安装尺寸 / Mounting Dimensions	166 (L) x 84 (W) mm 6-17/32" (L) x 3-5/16" (W)
本体重量 / Weight	1.6 kg 3.5 Lbs
导线长度 / Leadwire Length	285 mm 11-7/32"

用途例 / Application Examples

气缸 / 气动卡盘 / Air Cylinder/Chuck Driver

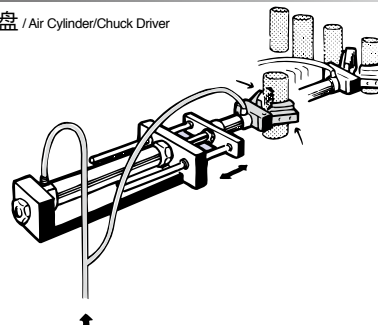

外形及安装尺寸图 / Dimensional Outline Drawing (单位 / Unit : mm)

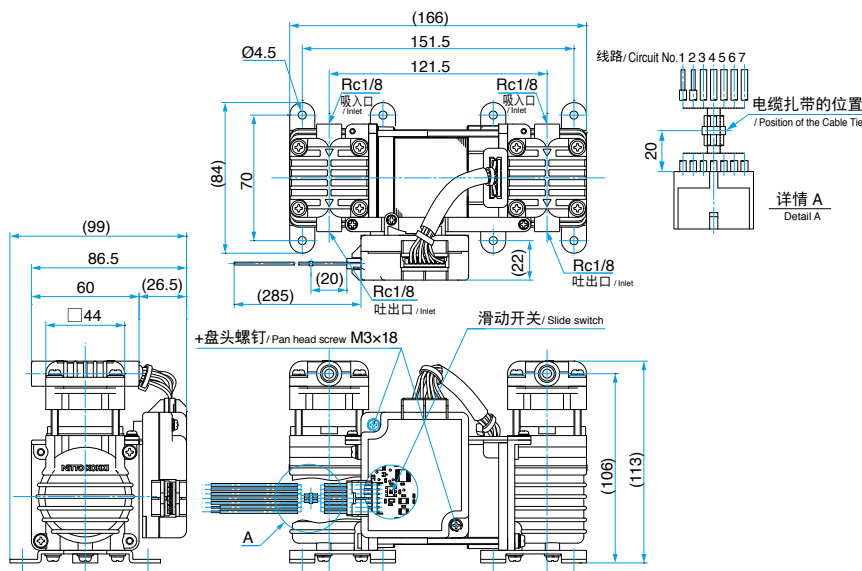

连接表 / Connection Table

线路 / Circuit No.	电源 / Power Source			控制信号 / Control Signal			
	1	2	3	4	5	6	7
颜色 / Cord Color	红色 / Red	黑色 / Black	褐色 / Brown	橙色 / Orange	黄色 / Yellow	绿色 / Green	灰色 / Gray
机能 / Function	V+	V-	驱动 / 自由 / DRIVE / FREE	脉冲 / PULSE	报警 / ALARM	速度 / SPEED	报警 / SGND
选项 / Option	无控制 / 功能关闭 / Function Off			OFF			
	有控制 / 功能开启 / Function On			ON			
线尺寸 / Cord Size	AWG20			AWG22			
线路类型 / Line Type	UL1007						

* 控制功能默认情况下是“OFF”
/ Control function is "OFF" by default.

- 务必使用扎带固定引线。(请参见细节 A。) 如果它们没有固定, 连接器可能会接触不良并导致故障。
- 有关接线的详细信息, 请参阅用户说明。
- Be sure to secure the lead wires with a cable tie. (See the detail A.) If they are not secured, poor contact of the connector may occur and result in failure.
- For the details of wiring, please see the user's instructions.